

KE-353 / KE-354 POUCH LOADER

Compact Body & Reasonable Price Chain Sachet FOLDING & CASING



Features

- **Stable casing** by moving the carton right/left & back/forth
- High capacity **32bit micro-computer** controlled
- Various options
 - Notch unit for preparing slits on vertical seal
 - Detect unit for sachet marking and contents shifts
 - Detect unit for detecting chain ends connection tape

Basic Specs

		KE-353	KE-354
Casing Capacity		50Hz: 150 sachets/minute 60Hz: 185 sachets/minute *at sachet length 70mm, 10pcs folding	
Work Material Size		Sachet width: Max. 100mm Sachet length: Max 150mm	
Case Dimension	Min.	400mm(W) × 200mm(D) × 100mm(H)	
	Max.	700mm(W) × 350mm(D) × 300mm(H)	710mm(W) × 510mm(D) × 310mm(H)
Accessories		Buffer box (Standard: 400mm (W) x 180mm (D) x 380mm (H) Power cable (5m)	
Dimension		900mm (W) × 570mm (D) × 1345mm (H)	900mm (W) × 820mm (D) × 1420mm (H)
Power		AC200/220V, 50/60Hz, Single Phase, 1.0kVA	
Weight		Approx. 80kg	

Overview

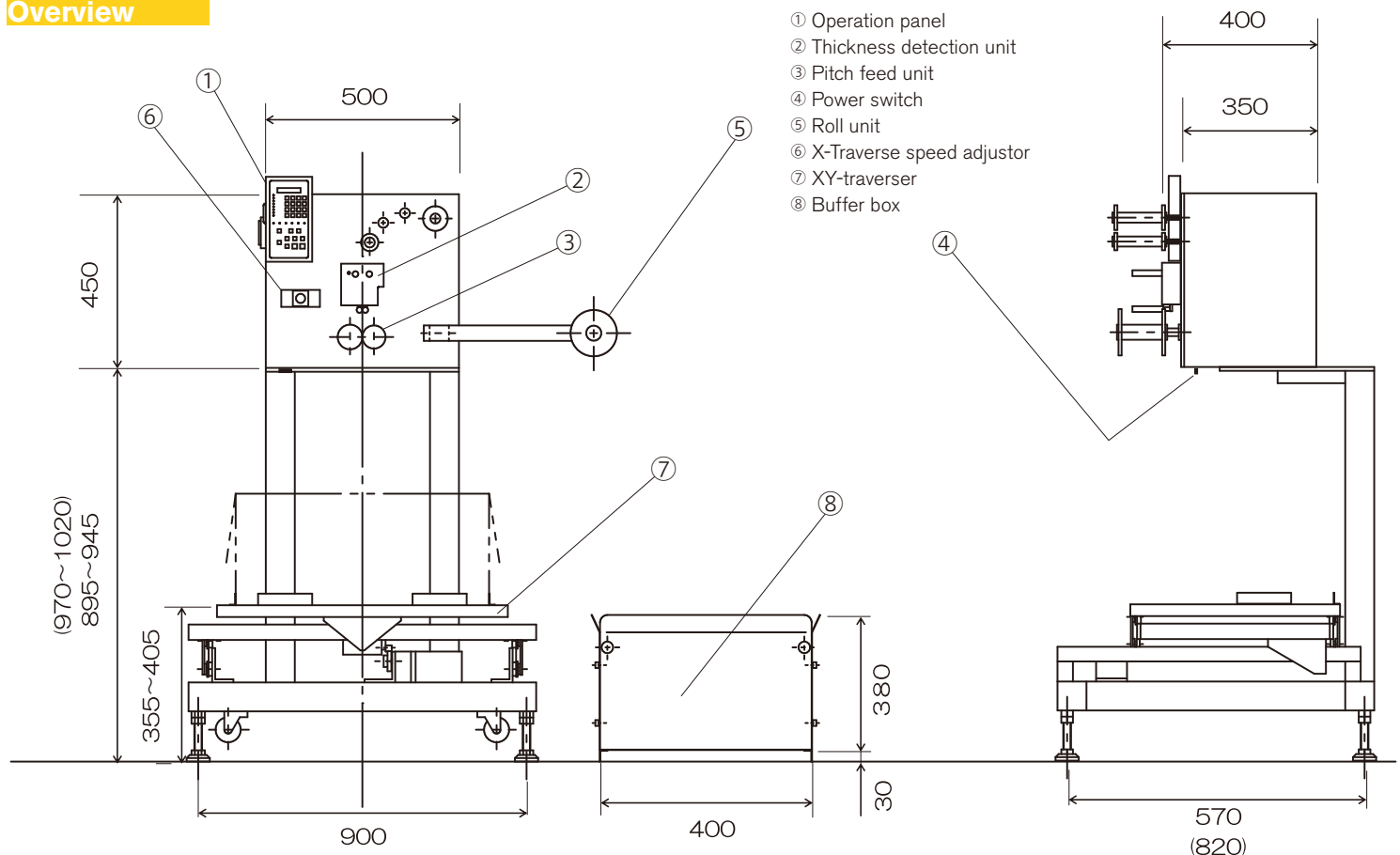

Lending “hands” to replace human hands.

www.mitsubishi-corp.co.jp

株式会社 三橋製作所

MITSUHASHI CORPORATION

□ Head Office/
Factory

1 Sekizan-cho Yamanouchi Ukyo-ku Kyoto
615-0082 Japan
TEL:+81-75-316-3300 FAX:+81-75-313-7595

□ Tokyo Office/
Overseas Sales Division

Yoshikuni Komagata Bldg. 9F 2-4-11 Komagata
Taitoh-ku Tokyo 111-0043 Japan
TEL:+81-3-3847-9751 FAX:+81-3-3847-9753

□ Kyushu Office

Minamikindai Building 6F, 4-2-10 Hakataekiminami
Hakata-ku Fukuoka 812-0016 Japan
TEL:+81-92-476-3800 FAX:+81-92-476-3801